

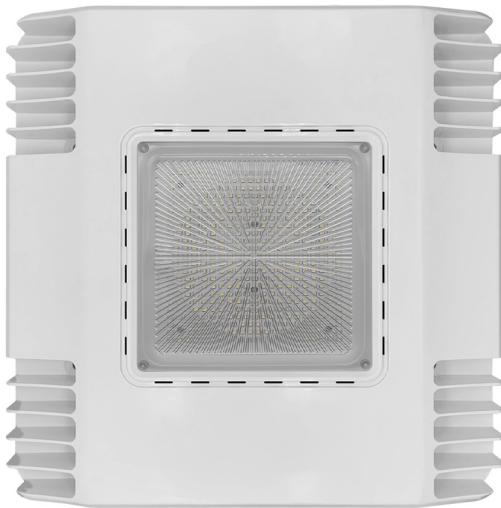

# Square Slim Canopy Light

## 150W Version



### Applications:

- Parking Lot Lighting
- Gas Station Lighting
- Commercial Lighting
- Canopy Replacement

### Product Information:

- Aluminum housing for heat dissipation
- High intensity: Ready to replace existing 400W fixture
- Suitable for retrofit with existing fixtures
- 100-277VAC
- PF >0.9 / Input: .85A/ Output: 36-66V DC
- 100° Beam Angle
- Operating Temperature: -40° F ~ 140° F
- Storing Temperature: -40° F ~ 185° F

### Why the EnVision Parking Garage Light:

- Optic lens provides forward and reverse throw light
- Easy installation with universal mounting plate
- 5 year limited warranty.
- Instant start, NO flickering, NO humming.
- IP65 Outdoor use

Series

**LED-CP2-WH-150W-50K**

150W • 18,000Lm

# Square Slim Canopy Light

M  
150W Version

## FEATURES

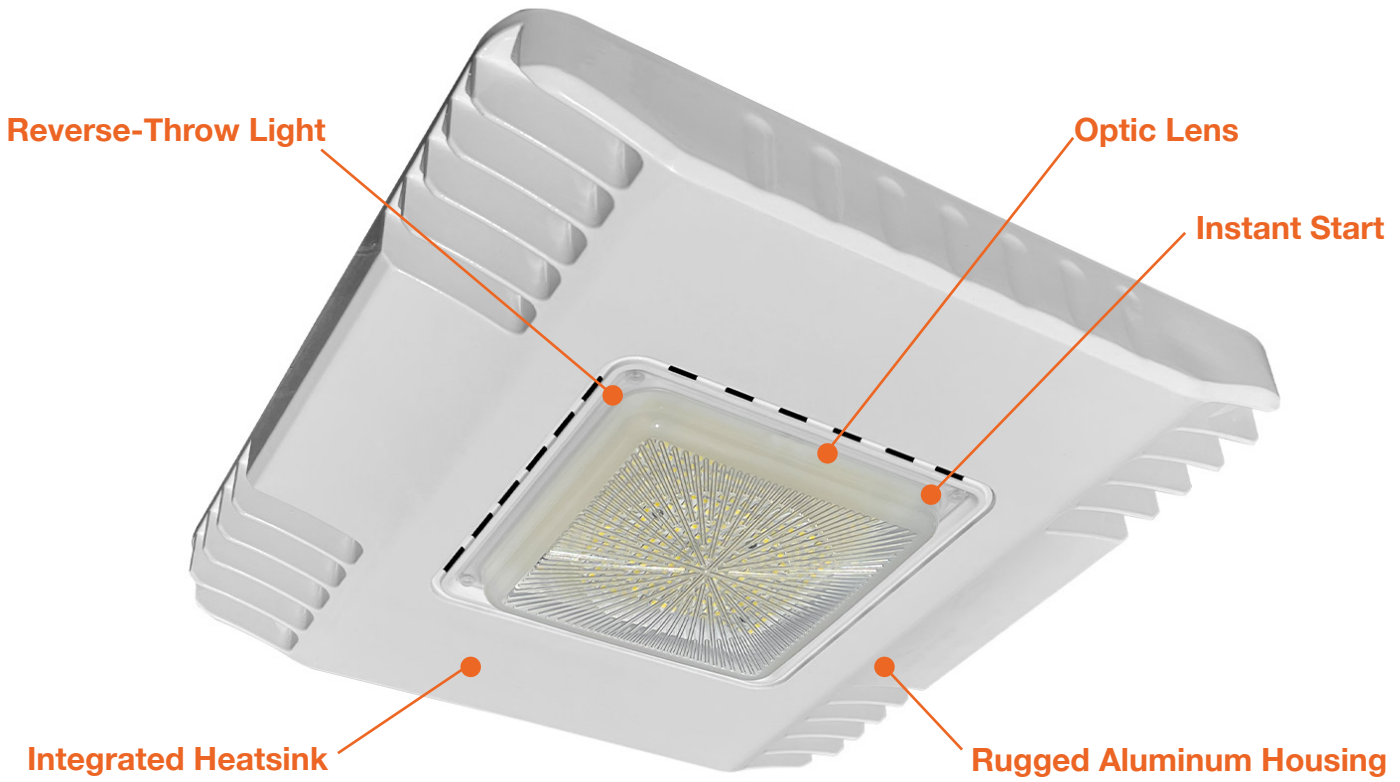

## DIMENSIONS

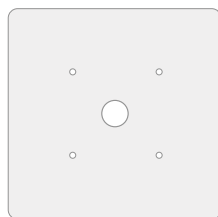
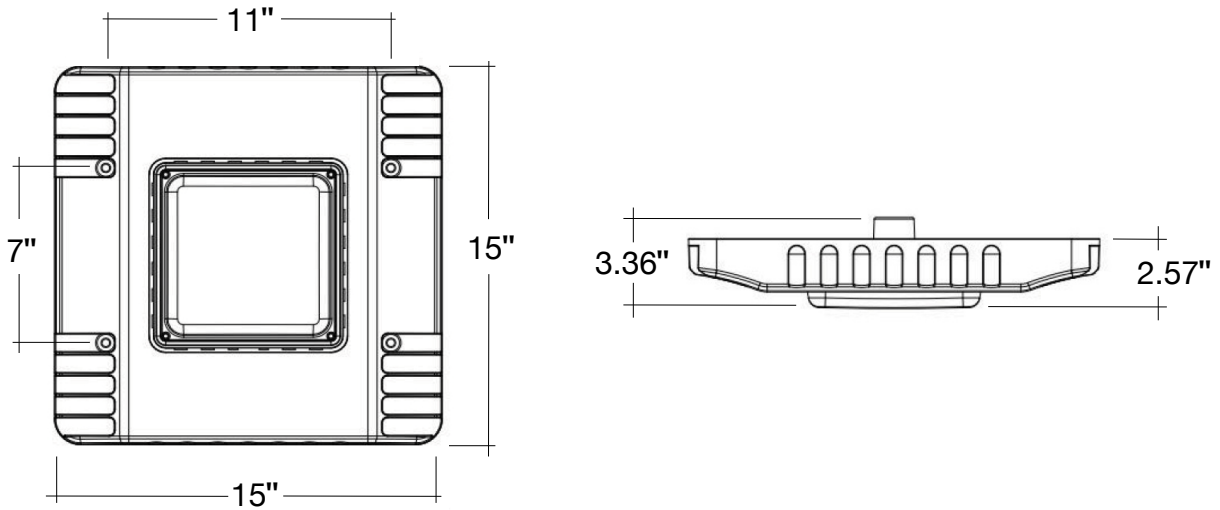

Accessory Model	Description
24x24-GF-CP2	24x24 Goof Ring

Specs and model numbers are subject to change with or without notice. Customization of product is available.