



Mini Flood Light: ARCY-Line

3-CCT/3-Power/Photocell Selectable



WATT	LUMENS
15	2,250
25	3,750
30	4,500
40	6,000
50	7,500
60	9,000
80	12,000
100	15,000

Detail Specifications:

- Finish: Bronze
- IP Rating: Wet Location (IP65)
- Beam Angle: NEMA 7Hx6V
- CCT: 30/40/50K Selectable
- Chip: SMD 2835, R9 >50, CRI >80
- Operating Temperature: -40° - 122° F
- Lens: PC Lens: Clear acrylic with optics
- Average life (L70) of 70,000 hours

Applications:

- Dock and Loading
- Walkways & Pathways
- Parking Lots
- Hospitality, Multi-Family
- Outdoor Corridors
- General Outdoor Lighting
- Residential, Commercial and Industrial

Product Information:

- Sturdy die-cast aluminum housing finished with corrosion free powder coat
- Photocell included on each fixture. Easy disconnect.
- 1.5' STJW 18.3 AWG cable whip included
- Select-n-Switch Technology
- Instant-On to full brightness

Driver Options:

- UNV: 120-277V 0-10V Dimmable
- Built in 6Kv Surge Protector
- THD: <20% (+/-5% tolerance), PF >0.9, 50/60Hz

Mounting & Installation:

- Two standard arms included in the box:
 - 1/2" Knuckle Mount (installed)
 - Trunnion Mount (loose)
- Adjustable 180° arms
 - 3P30: 0.37ft²
 - 3P60: 0.46ft²
 - 3P100: 0.68ft²

Certifications:

- UL Listed for USA and CA
- DLC Listed
- ROHS Compliant
- Approved for CA T24
- 5 Year Limited Warranty
- FCC CFR 47, GCC Part 15, Subpart B:2017

Series

LED-ARL3-ARC-3P30-TRI-BZ-UNV-KNT-PC

15/25/30W

LED-ARL3-ARC-3P60-TRI-BZ-UNV-KNT-PC

40/50/60W

LED-ARL3-ARC-3P100-TRI-BZ-UNV-KNT-PC

60/80/100W

Mini Flood Light: ARCY-Line

3-CCT/3-Power/Photocell Selectable

FEATURES



Aluminum Die-Cast



Photocell Switch

3-CCT Selectable Switch



Knuckle Mount



Trunnion Mount Included

DIMENSIONS

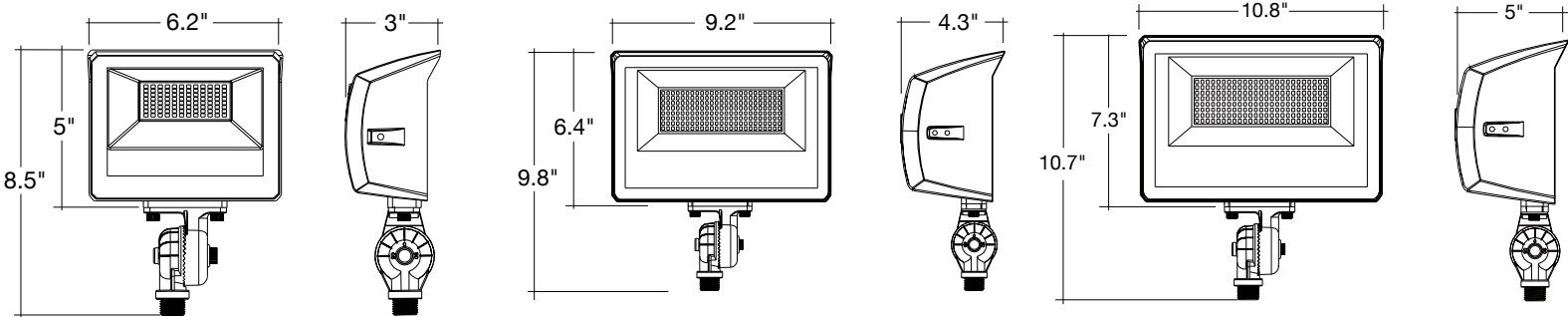

30W

60W

100W