

LED Retrofit Troffer Installation Instructions



Please read and understand this entire manual before attempting to assemble, operate or install the product.

LED retrofit kit troffer are not suitable for using in wet locations.

LED retrofit kit troffer are not suitable for covering with thermally insulating material.

Please keep the LED retrofit kit troffer way from any corrosive substance, and please use dry cloth when you clean it.

LED retrofit kit troffer can only be installed by a qualified electrician.

Before installation or maintenance, please disconnect the power to prevent electric shock.

Product parameters

Part No.	Power	Working Current	Input Voltage	Luminous Efficacy	CCT	Viewing Angle	Ra	PF	Dimmable	Warranty
TAA22-RT-40W-S-TCP	20W/30W/40W	0.367A	AC120-277V	125lm/W	3500K/ 4000K/ 5000K	120°	≥80	≥0.9	0-10V	5 Years
TAA24-RT-50W-P-TCP	30W/40W/50W	0.458A								

Product dimensions

Part No.	TAA22	TAA24	
Dimension (inch)	L	22.76"	46.75"
	W	21.05"	21.05"
	H	2.11"	2.11"

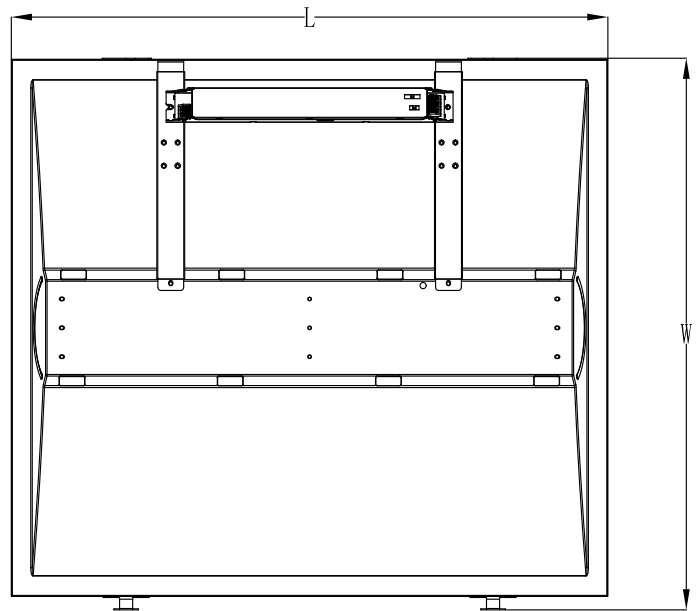
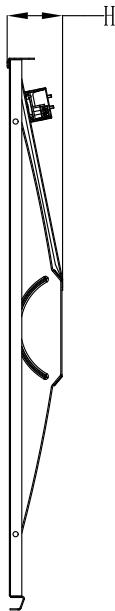

Installation Guide

1. Disconnect power to the existing fixture.

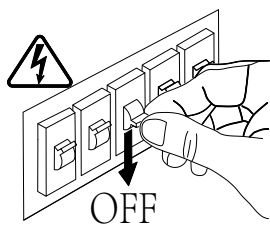

2. Please remove the existing fixture's cover, fluorescent lamps, lamp-holders and ballast etc. from the frame.

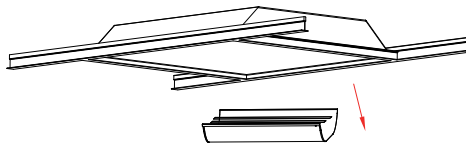

3. Slide in both side-mounting brackets between the existing frame and "T" grid.

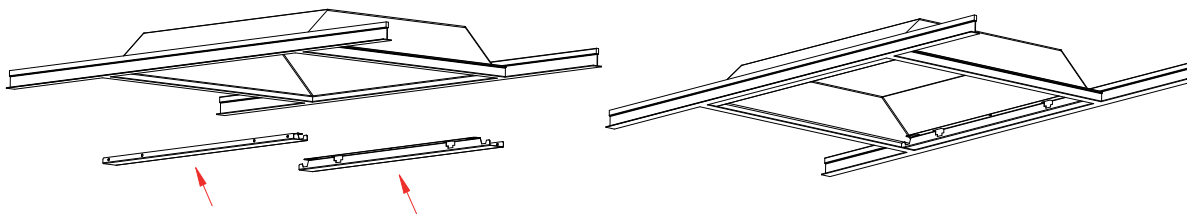

4. Hook the retrofit kit troffer body to the existing frame through the clasps in body to the side-mounting bracket.

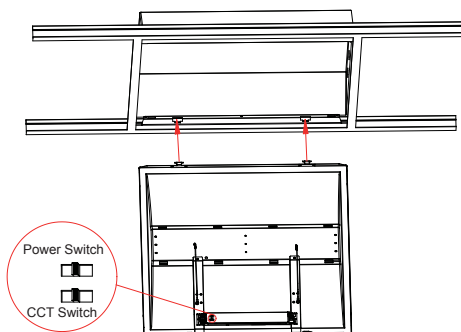

5. As shown in the figure, the retrofit kit troffer body is suspended and hooked to side-mounting bracket, make sure it is clamped tightly.

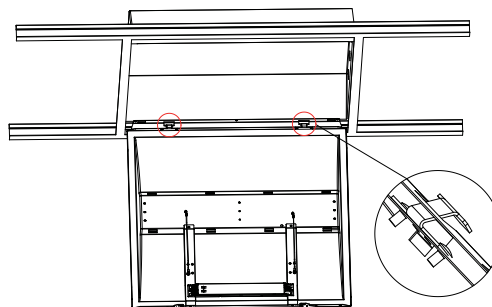

6. Hook the retrofit kit troffer safety rope to the hole of corresponding side-mounting bracket, suspend the retrofit kit troffer body.

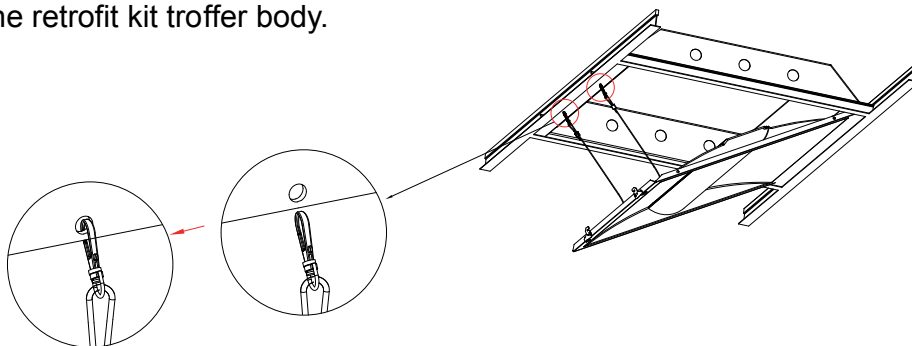

7. Install the power disconnected to line (black) and neutral(white) coming into fixture, ground wires, connect dimming wires (purple & pink), and screw with wire nuts in a suitable place where no loosening.

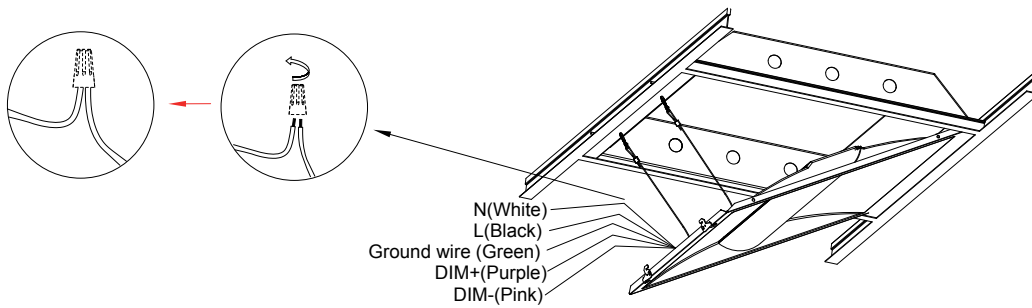

8. Rotate the retrofit kit troffer body upward, push it to the surface of side-mounting bracket.

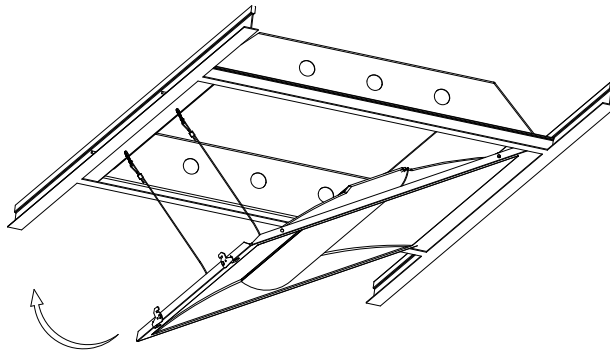

9. Push the retrofit kit troffer body to secure latches, until hearing a "click" sound to ensure it fastened tightly.

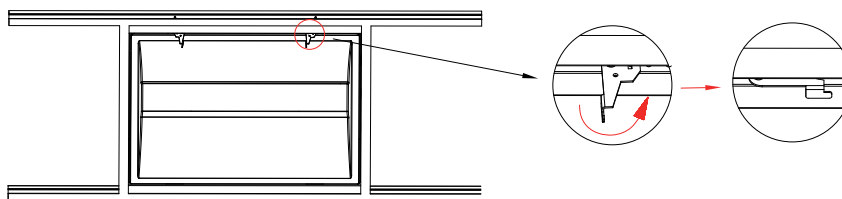

10. Installed view picture shown as below.

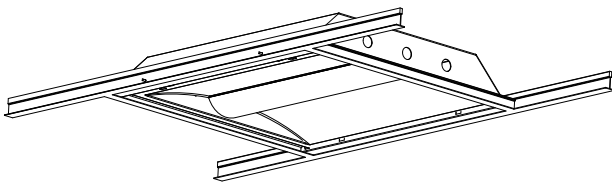

11. Reconnect the power to light on.

