

Installation Instructions



Please read and understand this entire manual before attempting to assemble, operate or install the product.

WARNING: First please read all product labels and instruction before installing fixture. Risk of fire or electric shock. LED Retrofit Kit installation requires knowledge of luminaire electrical systems. Installation should be performed only by a qualified electrician in accordance with the National Electrical Code and relevant local code. Install this kit only in the luminaires that have the construction features and dimensions shown in the photographs and/or drawings. To prevent wiring damage or abrasion, do not expose wiring to edges of sheet metal or other sharp objects. Do not make or alter any open holes in an enclosure of wiring or electrical components during kit installation. The recessed luminaire is intended for mounting only in a covered ceiling where only the LED side of the luminaire will be exposed to damp or dry locations.

INSTALLATION SHOULD ONLY BE PERFORMED AFTER POWER TO THE FIXTURE HAS BEEN DISCONNECTED. THIS RETROFIT KIT IS ACCEPTED AS A COMPONENT OF A SUITABILITY OF THE COMBINATION SHALL BE DETERMINED BY AUTHORITIES HAVING JURISDICTION.

Product Information

MODEL NO.	SIZE	D1	D2	H	CUT-OUT
LED-CMD-4-3M19-5CCT-UNV	4"	6"	4 3/4"	4 3/16"	Ø4 15/16"
LED-CMD-6-3M19-5CCT-UNV	6"	8 7/16"	5 7/8"	4 13/16"	Ø6 1/8"
LED-CMD-6-3M30-5CCT-CUNV	6"	8 7/16"	5 7/8"	4 13/16"	Ø6 1/8"
LED-CMD-8-3M29-5CCT-UNV	8"	10 1/16"	7 3/8"	5"	Ø7 9/16"
LED-CMD-8-3M36-5CCT-CUNV	8"	10 1/16"	7 3/8"	5"	Ø7 9/16"
LED-CMD-10-3M386-5CCT-UNV	10"	11 3/8"	8 11/16"	5 1/2"	Ø9"

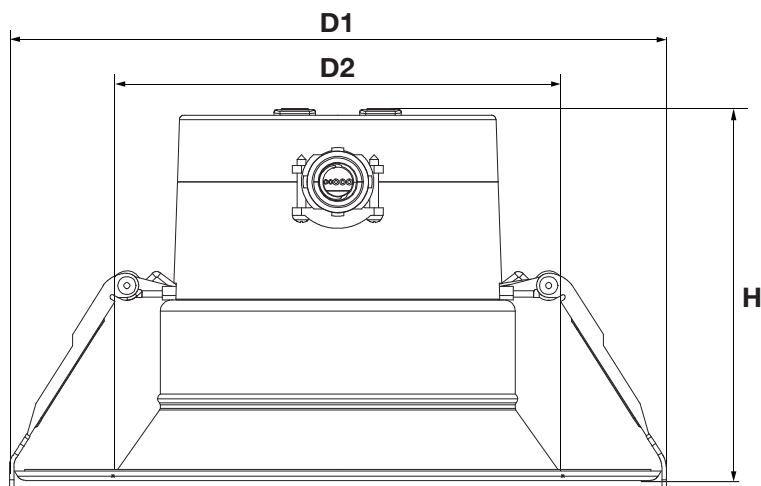

Envision LED wattage and CCT tunable commercial round LED recessed downlight fixture, allows for selecting between three power and light temperature settings to match a wide range of applications. With a Color Rendering Index (CRI) of 90, one can expect objects to display excellent color accuracy. The wattage tunable selector switch on the fixture's back, allows the user to choose different power while the CCT tunable selector before installation.

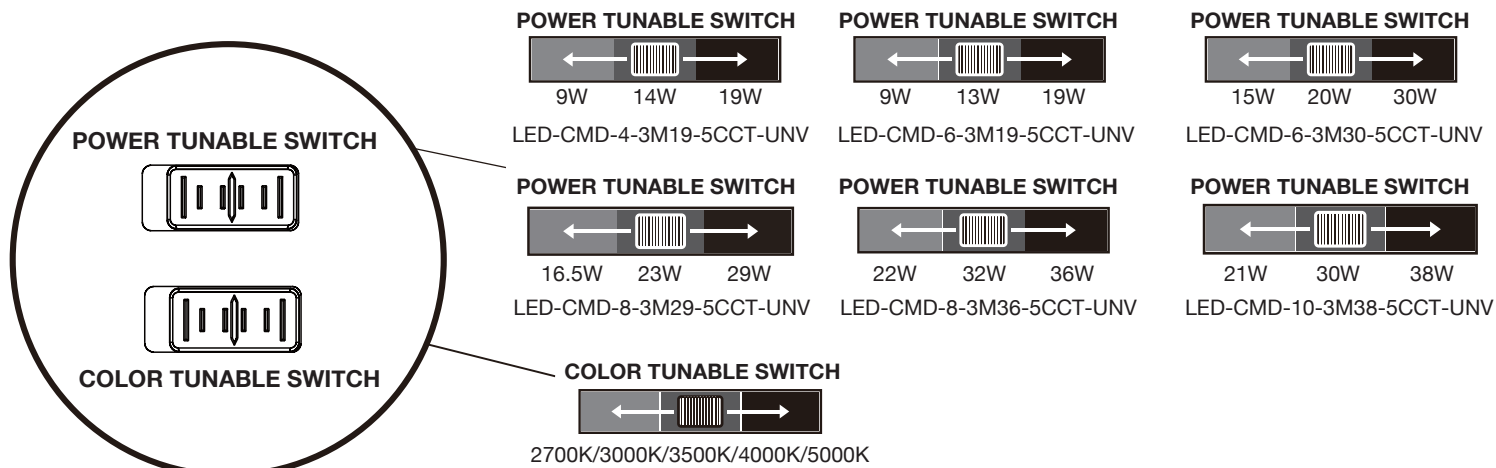

Retrofit Installation

Note: The class 2 constant driver, for risk of electric shock. The junction box needs to connect the "Earth Wire".

Step 1: Make sure the POWER is TURNED OFF while you are installing the products.

Step 2: Choose CCT & lumens for your choice of light (Fig. 1).

Step 3: If existing lamp and trim are present, remove from ceiling or move it out of the way as it will not be needed during installation. Measure the ceiling opening to make sure the edge of the luminaire will cover the entire hole and still sit firmly in the ceiling before proceeding (Fig 2).

Step 4: Attach the carabiner safety clip to the existing fixture housing (Fig. 3).

Step 5: Insert lamp conduit into the J-box and wire to power source (black to hot, white to neutral, violet to 0-10V dimming positive, pink to 0-10V dimming negative) (Fig. 4). Reattach J-box cover when complete.

Step 6: Squeeze the two housing clips so they are in an upright position and insert lamp into housing (Fig. 5)

Step 7: Once lamp is inside the housing, release the housing clips and continue pushing lamp into housing until securely fixed and flush with ceiling (Fig. 6)

Step 8: Restore power at the source, installation is complete.

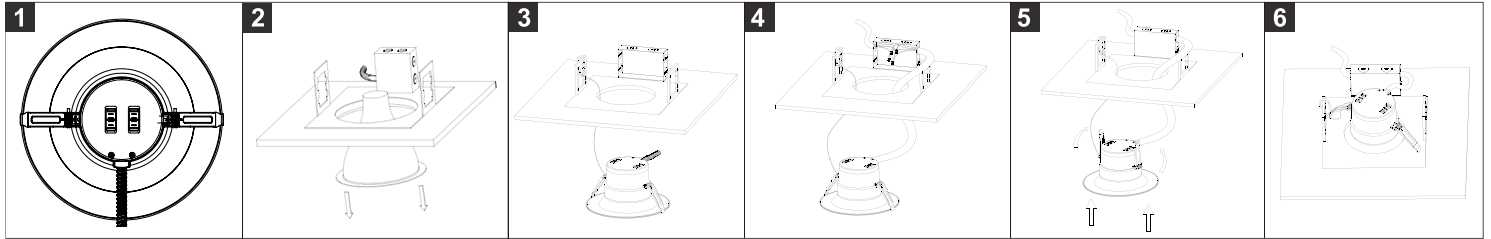

New Construction Installation

Note: The class 2 constant driver, for risk of electric shock, The junction box needs to connect the "Earth Wire".

Step 1: Make sure the POWER is TURNED OFF in which you are installing the product;

Step 2: Choose CCT & lumens what's you want by dip switch (Fig. 1)

Step 3: Attach the carabiner safety clip to the existing fixture housing (Fig. 7)

Step 4: Insert lamp conduit into the J-box and wire to power source (black to hot, white to neutral, violet to 0-10V dimming positive, pink to 0-10V dimming negative) (Fig. 8). Reattach J-box cover when done

Step 5: Squeeze the two housing clips so they are in an upright position and insert lamp into opening (Fig.9)

Step 6: Once lamp is inside the opening, release the housing clips and continue pushing lamp into

Step 7: Restore power at the souree and the instalation is Complete,

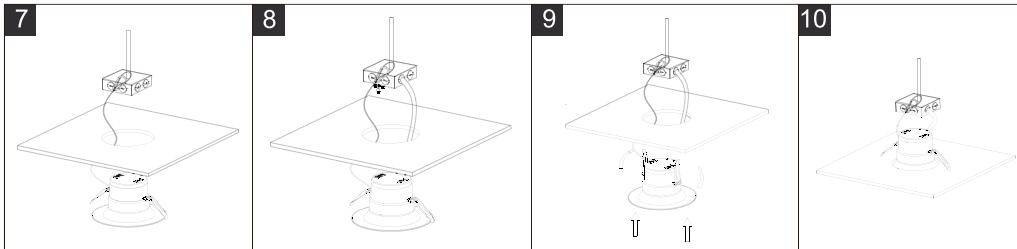

Changes or modifications to this unit not expressly approved by the party responsible for compliance could void the user's authority to operate the equipment.

NOTE: This equipment has been tested and found to comply with the limits for a Class B digital device, pursuant to Part 15 of the FCC rules. These limits are designed to provide reasonable protection against harmful interference in a residential installation. This equipment generates, uses and can radiate radio frequency energy, if not installed and used in accordance with the instructions, may cause harmful interference to radio communications. However, there is no guarantee that interference will not occur in a particular installation. If this equipment does not cause harmful interference to radio or television reception, which can be determined by turning the equipment off and on, the user is encouraged to try to connect the interference by one or more of the following measures:

- Relocate or adjust the receiving antenna.
- Increase the separation between the equipment and receiver.
- Connect the equipment into an outlet on a circuit different from that to which the receiver is connected.
- Consult the dealer or an experienced radio/TV technician for help.

The class 2 constant driver, for risk of electric shock, The junction box needs to connect the "Earth Wire".

Step 1: Make sure the POWER is TURNED OFF in which you are installing the product;

Step 2: Choose CCT & lumens what's you want by dip switch (Fig. 1)

Step 3: Attach the carabiner safety clip to the existing fixture housing (Fig. 7)

Step 4: Insert lamp conduit into the J-box and wire to power source (black to hot, white to neutral, violet to 0-10V dimming positive, pink to 0-10V dimming negative) (Fig. 8). Reattach J-box cover when done

Step 5: Squeeze the two housing clips so they are in an upright position and insert lamp into opening (Fig.9)

Step 6: Once lamp is inside the opening, release the housing clips and continue pushing lamp into

Step 7: Restore power at the souree and the instalation is Complete,