

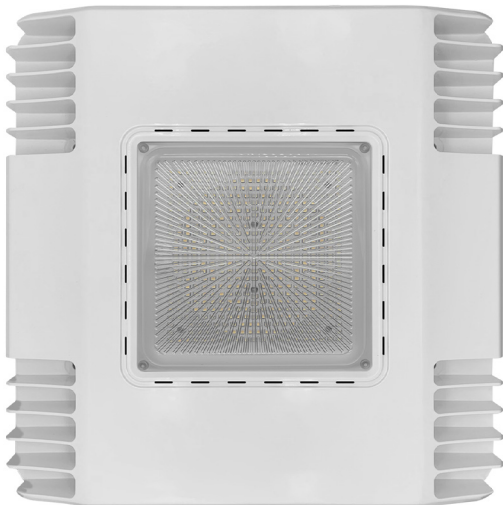

Large Square Canopy: Slim-Line

2CCT: 40/50K Selectable



Detail Specifications:

- Finish: White
- IP Rating: Wet Location (IP65)
- Wattage: 150W
- Lumens: 18,000
- Beam Angle: 150°
- Chip: SMD 2835, R9 >50, CRI >80
- Operating Temperature: -4° - 124° F
- Lens: PC, Clear Ribbed
- Average life (L70) of 50,000 hours

Applications:

- Gas Stations
- Utility & Storage
- Garage & Parking Structures
- Dock and loading
- Soffits
- Outdoor corridor
- Commercial and Industrial

Product Information:

- Sturdy die-cast aluminum housing finished with corrosion free powder coat
- Select-n-Switch Technology: 2-CCT

Driver Options:

- UNV: 120-277V, 0-10V Dimmable
- THD: <20% (+/-5% tolerance), PF >0.9, 50/60Hz
- Isolated Driver
- Flicker Free

Mounting & Installation:

- 30 or 40 J-Box Surface Mount

Certifications:

- UL Listed for USA and CA
- DLC Premium Listed
- ID: PENDING 6/15
- Approved for CA T24
- 5 Year Limited Warranty
- FCC CFR 47, GCC Part 15, Subpart B:2017

Series	Finish	Wattage	CCT
LED-CP2 - WH - 150W - 40/50K	White		4000/5000K

Accessories

Goof Plate

24X24-GF-CP2

24x24 Goof Ring

Custom

Custom Sizes Available

Large Square Canopy: Slim-Line

2CCT: 40/50K Selectable

FEATURES

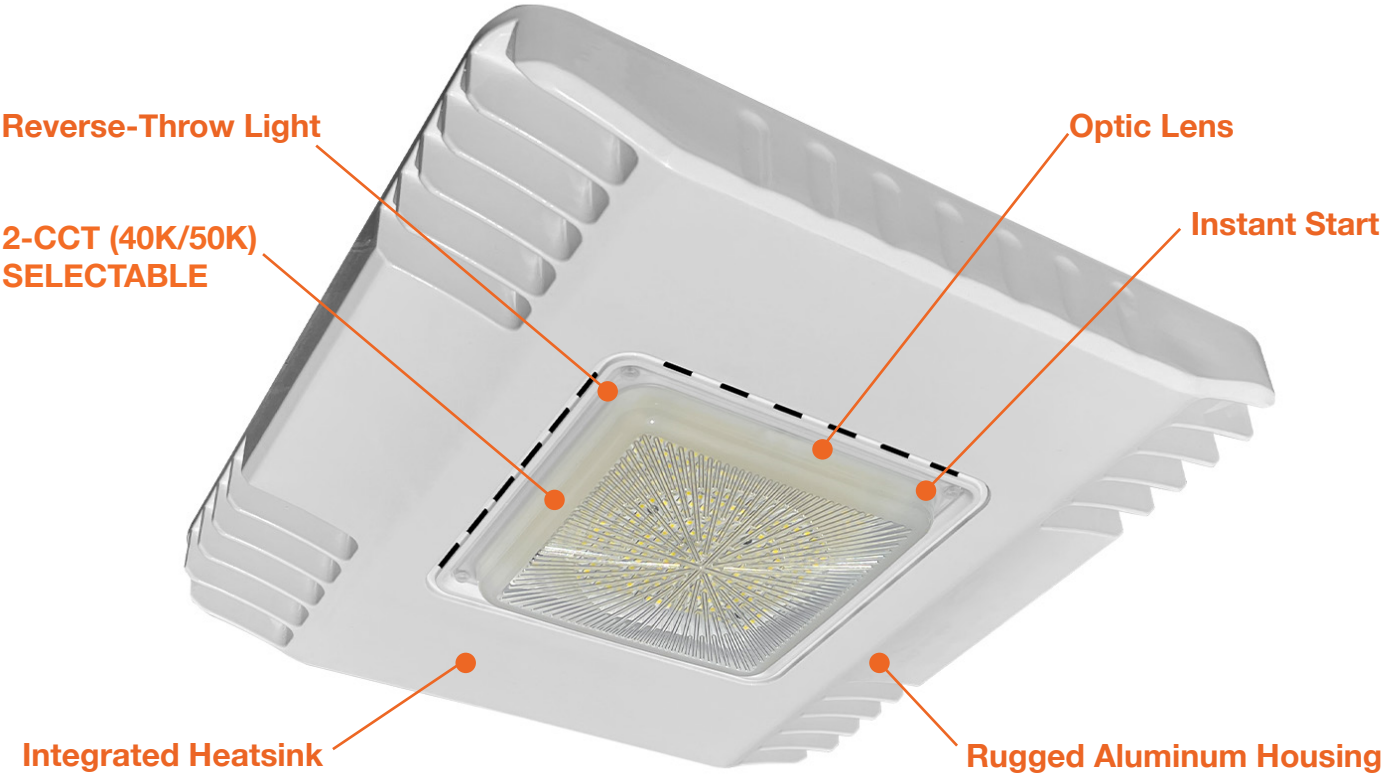

DIMENSIONS

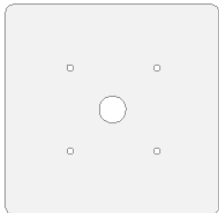
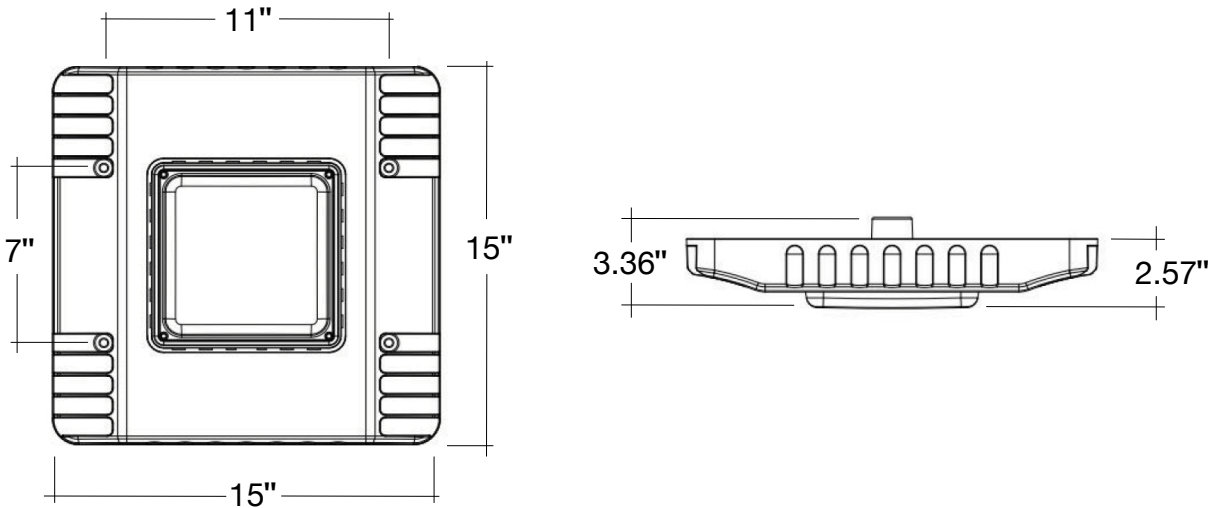

Accessory Model	Description
24x24-GF-CP2	24x24 Goof Ring

Specs and model numbers are subject to change with or without notice. Customization of product is available.