

# Emergency LED Driver

Emergency Battery Backup



**Features:**

- Simple wiring: Directly connect to LED driver AC input
- Constant power output 30W
- Universal input range, 100-347Vac, 50/60Hz
- High output voltage DC 175V
- Optimized design for UFO highbay fixtures
- Protection: Over-voltage, short-circuit, over-load open-circuit
- Self-diagnostic every month and year
- Wireless remote control for emergency test
- UL listed for factory and field installation
- CEC Title 20 and US DOE emergency efficiency

INPUT VOLTAGE	100-347VAC 50/60Hz	Test Switch Charge Indicator Light	Remote Control
OUTPUT VOLTAGE	≤ 175V DC	Battery	Li-ion Battery
INPUT CURRENT	≤ 200mA	Charging Time	≥ 24 Hours
INPUT POWER	15W	Output Power	30 Watt
EMERGENCY TIME	90 Minutes	Weight	7.3 Lbs
WARRANTY	5 Years	Dimensions	10 x Ø5in
AMBIENT TEMP	0°F to +122°F		



ON/OFF CONTROL



MOUNT UP TO 50FT

Remote Control  
Optional

*Series*

**LED-EMB-30W-HV-UFO-BL**  
**LED-EMB-30W-HV-UFO-WH**

*Optional Accessories  
(Order Separately)*

*Remote Control*

**RC**

# Emergency LED Driver

## FEATURES



WATERPROOF RUBBER SEAL



LED CHARGING INDICATOR



WIRE ACCESS

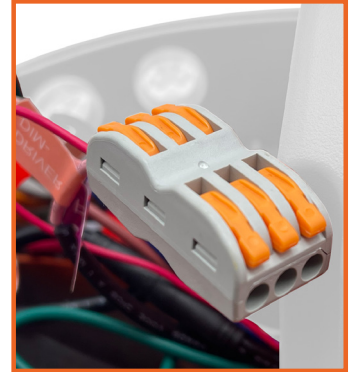

QUICK WIRE CONNECT



CABLE SUPPORT



SAFETY HOOK / EYE LET



INSIDE EMERGENCY LED DRIVER



REMOTE CONTROL (OPTIONAL)

## DIMENSIONS

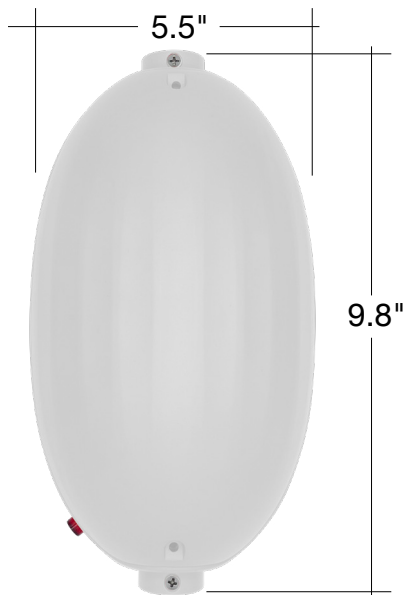

# Emergency LED Driver

## WIRING DIAGRAM

### 1 With Dimmer

For UFO LED Highbay  $\leq 300W$  and have 0-10V dimming function

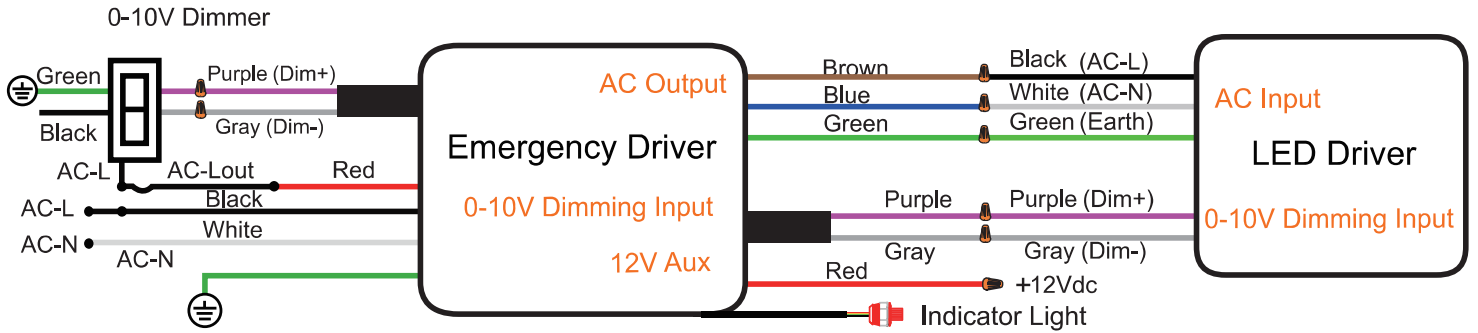

#### IMPORTANT

Dimming wires must be connected to UFO LED Driver dimming wires for EM to function properly. Will NOT operate if not connected.

#### RECOMMENDATION

Emergency Output Power  $\geq 20\%$  Output Power of UFO LED High Bay

### 2 With Wall Switch Without Dimmer

For UFO LED Highbay  $\leq 300W$  and have 0-10V dimming function

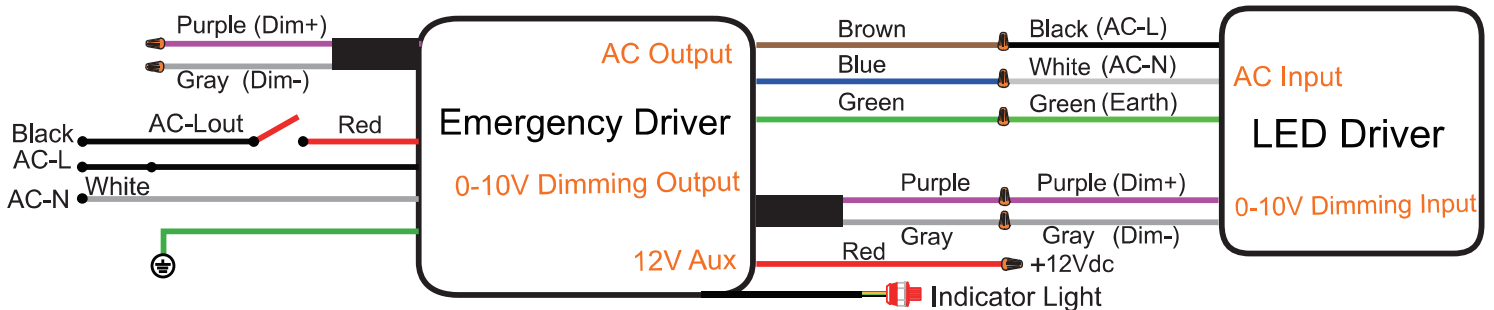

#### IMPORTANT

Dimming wires must be connected to UFO LED Driver dimming wires for EM to function properly. Will NOT operate if not connected.

#### RECOMMENDATION

Emergency Output Power  $\geq 20\%$  Output Power of UFO LED High Bay

# Emergency LED Driver

## WIRING DIAGRAM

### 3 Without Wall Switch & Dimmer, 24Hr Lighting

For UFO LED Highbay  $\leq 300W$  and have 0-10V dimming function

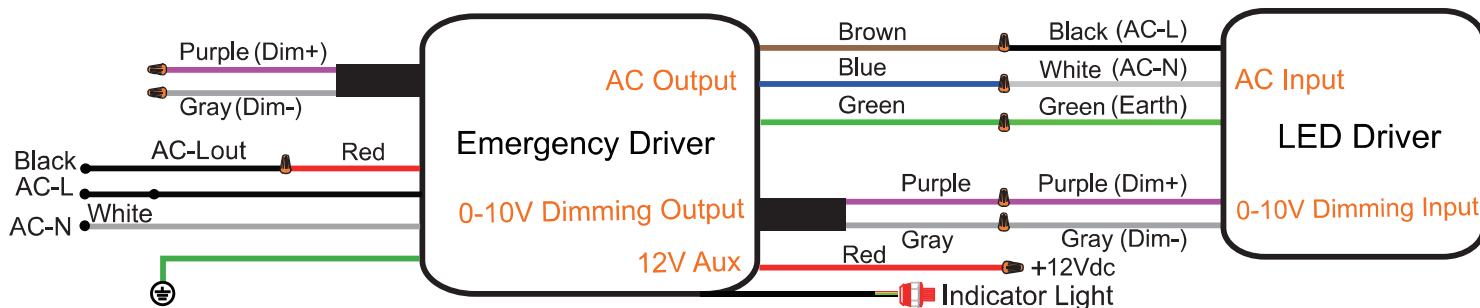

#### IMPORTANT

Dimming wires must be connected to UFO LED Driver dimming wires for EM to function properly. Will NOT operate if not connected.

#### RECOMMENDATION

Emergency Output Power  $\geq 20\%$  Output Power of UFO LED High Bay

### 4 With Sensor (100-347 VAC)

For UFO LED Highbay  $\leq 300W$  and have 0-10V dimming function

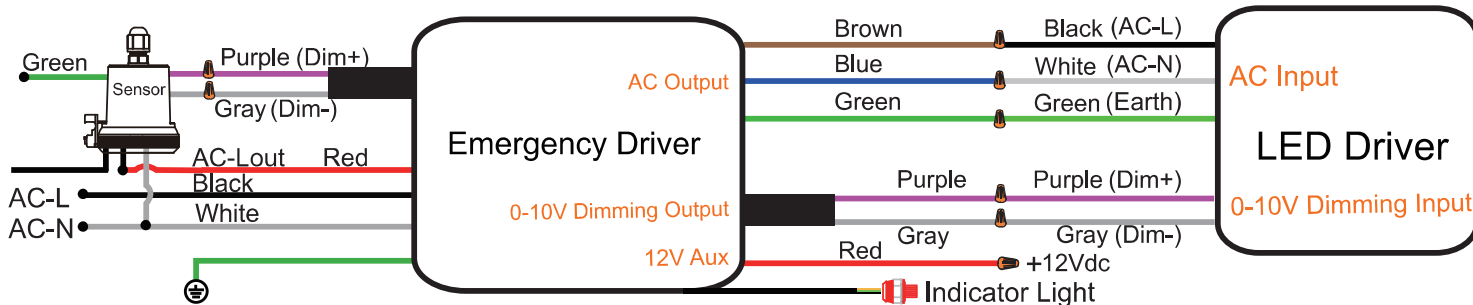

#### IMPORTANT

Dimming wires must be connected to UFO LED Driver dimming wires for EM to function properly. Will NOT operate if not connected.

#### RECOMMENDATION

Emergency Output Power  $\geq 20\%$  Output Power of UFO LED High Bay

# Emergency LED Driver

## WIRING DIAGRAM

- 5 With 12VDC Sensor**  
For UFO LED Highbay  $\leq 300\text{W}$  and have 0-10V dimming function

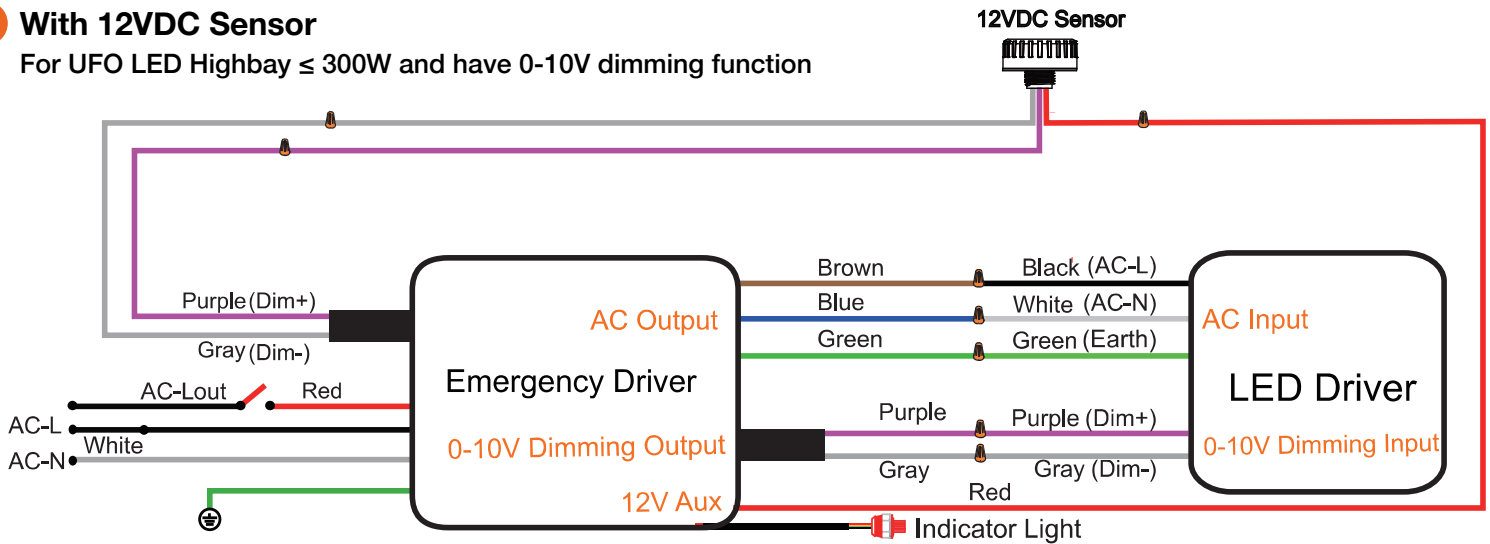

### IMPORTANT

Dimming wires must be connected to UFO LED Driver dimming wires for EM to function properly. Will NOT operate if not connected.

### RECOMMENDATION

Emergency Output Power  $\geq 20\%$  Output Power of UFO LED High Bay

## Self Diagnostic

The integrated self-diagnostic circuitry will automatically conduct monthly 30-min and annual 90-min test to verify proper emergency capability per Life Safety Code requirements. Press the test button to cut the power to the AC driver and switch the system to emergency mode. NFPA 101, Life Safety Code outlines the following schedule.

**Monthly-** Insure that the test button light is illuminated. Conduct a 30 second discharge test by depressing the test button. The LED load should operate at reduced output.

**Annually -** Insure that the test button is illuminated. Conduct a full 90 minute discharge test. The unit should operate as intended for the duration of the test, written records of the testing shall be kept by the owner for inspection by the authority having jurisdiction.

# Emergency LED Driver

## OPERATING INSTRUCTIONS

Type A Pole Mount

Type B Pole Mount

Type C Ring Mount

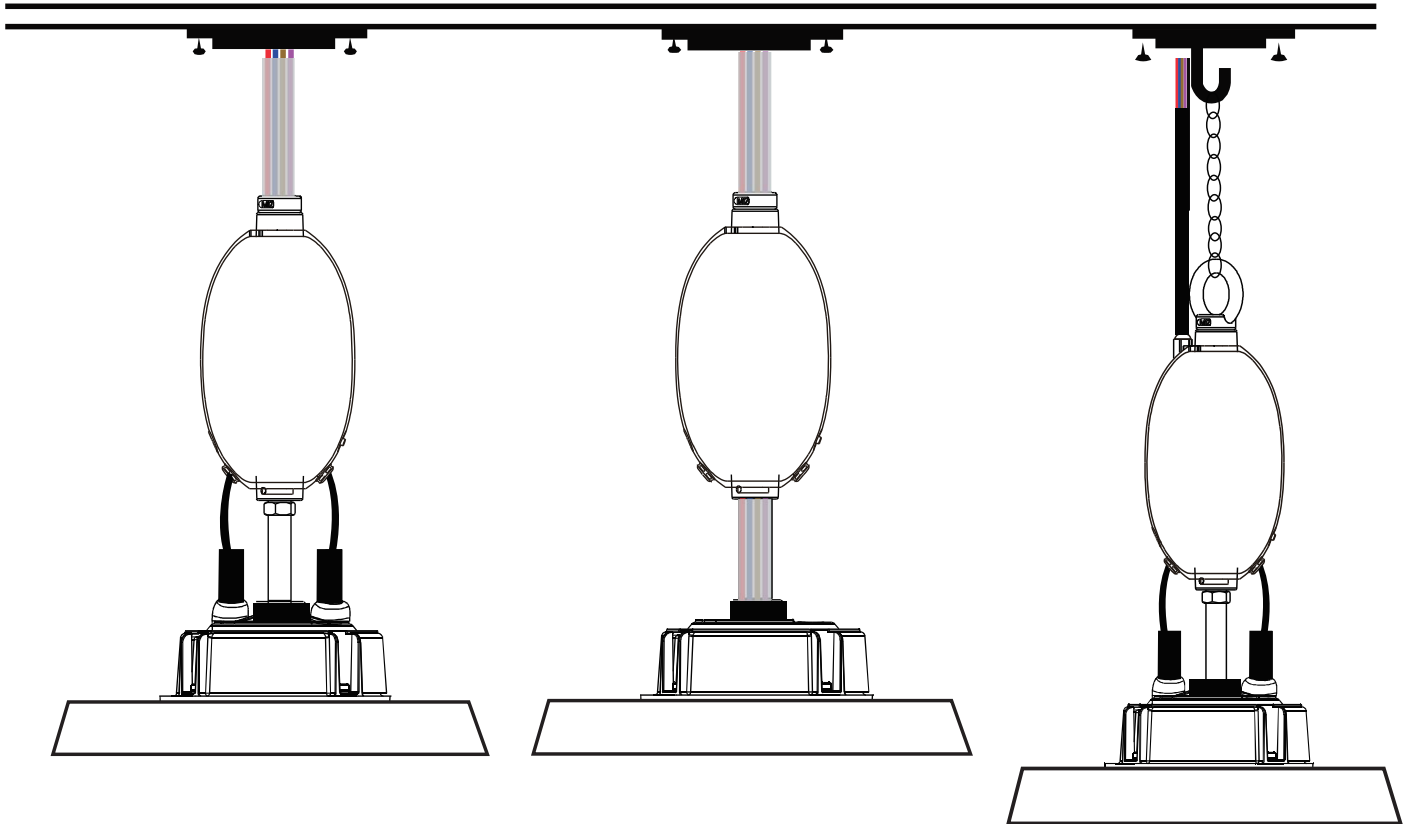

## Instructions for Remote Control



### Testing

Press the ON button to test emergency function. The light will switch to its emergency lighting and the indicator light will turn OFF. Press the OFF button, the light will return to normal lighting. When main supply is OFF (Emergency Mode), press the OFF button to turn OFF emergency function.

### Please Note

Remote control must be pointed at the indicator light and be within a 45° angle to receive signal/command. Controller needs two AAA batteries to operate (not included).

# Emergency LED Driver

## READ AND FOLLOW ALL SAFETY INSTRUCTIONS

- Risk of fire or electric shock. Luminaire wiring and electrical parts may be damaged when drilling for installation of LED Emergency Backup. Check enclosed wiring and components.
- Risk of fire or electric shock. This LED emergency backup installation requires knowledge of luminaire electrical systems. If not qualified, do not attempt installation. Contact a qualified electrician.
- Before installing, make certain the AC power to the fixture is OFF.
- The electrical rating of this product is 100-347 Vac. Installer must confirm that there is 100-347 Vac to the fixture before installation.
- To prevent electrical shock only mate unit connector after installation is complete and before the AC power to the fixture is back on.
- Do not use outdoors
- This LED emergency backup unit requires an un-switched AC power source of 100-347 Vac, 50/60Hz. The AC driver must be on the same branch circuit as the LED emergency backup unit.
- Do not let power supply cords touch hot surfaces.
- Do not mount near gas or electric heater.
- Do not connect battery pack connector until all other wiring is complete and AC power is on.
- Equipment should be mounted in locations and at heights where it is not be subjected to tampering by unauthorized personnel.
- The use of accessory equipment is not recommended by the manufacturer and may cause an unsafe condition.
- Do not use this equipment for other than its intended use.
- Use with grounded, UL listed, dry or damp location rated fixtures.
- Make sure the load is not greater than 300W, more than its parameter will result in shortening discharge time.
- Repairs and maintenance must be carried out by qualified personnel.