

Directional Retrofit Lamp

3-Power Selectable

LED Bulbs



The EnVision LED flat directional HID replacement lamp allows the end user to retrofit existing shoebox, wall pack, and flight light housings. The lamp includes an internal driver with a 6kV surge protector inside.

Detail Specifications

- IP Rating: IP64 Wet Location
- Beam Angle: 120°
- Base: EX39
- CCT: 5000K standard (30,40,57k available custom order)
- Chip: SMD 2835, R9 >50, CRI >80
- Operating Temperature: -40° - 122° F
- Average life (L70) of 50,000 hours

Applications:

- Outdoor Lighting
- HID Lamp Replacement
- Shoebox, Wall Pack, Flood Light Retrofit
- Residential, Commercial and Industrial

Product Information:

- Aluminum housing for heat dissipation
- Suitable for use in existing fixtures
 - Ballast bypass required
- Connect directly to 120-277V power
- Instant-On to full brightness

Driver Options:

- 120-277V
- 0-10V Dimmable
- THD: <20% (+/-5% tolerance), PF >0.9, 50/60Hz

Mounting & Installation:

- EX39 socket
- Ballast bypass required

Certifications:

- UL Listed for USA and CA
- DLC Listed
- 5 Year Limited Warranty
- FCC CFR 47, GCC Part 15, Subpart B:2017

3P54

WATT	LUMENS
36	4,140
45	5,175
54	6,210

3P115

WATT	LUMENS
75	8,625
95	10,925
115	13,225

Series

LED-FLL-3P54-50K-EX39

54/45/36w

LED-FLL-3P115-50K-EX39

115/95/75w

Directional Retrofit Lamp

3-Power Selectable

FEATURES

Multiple Applications

Security Cable Hanger

High Quality LED Chips

Grade A Heat Sync



EX39 Base
Larger & Wider
Tip Base



**3-Watt & 3-CCT
Selectable**



**Security
Cable**

DIMENSIONS

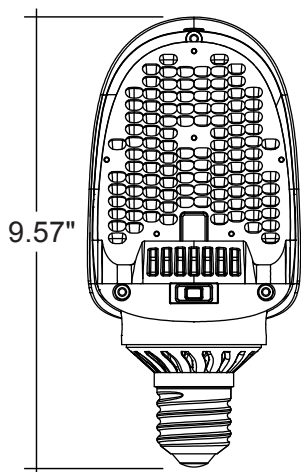

3P54

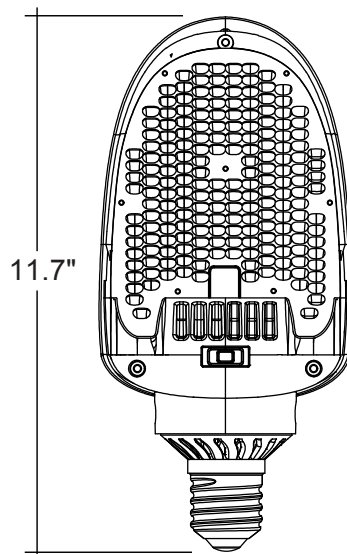
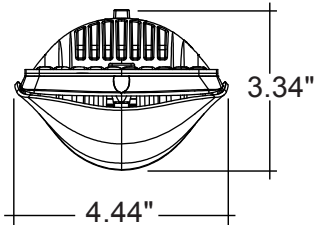

3P115

