

Internal-Line: Surface Mount LED Panels

Only 1" Thick!



Detail Specifications:

- Finish: White, Custom finishes available
- IP Rating: Damp Location
- Beam Angle: 110°
- Chip: SMD 2835, R9 >50, CRI >80
- 3 Step MacAdam Ellipses
- Operating Temperature: -40° - 114° F
- Lens: PMMA Frosted
- Average life (L70) of 50,000 hours

Applications:

- General Indoor Lighting
- Utility & Storage
- Office and Meeting Rooms
- Education, Healthcare, Retail, Hospitality
- Residential and Commercial

Product Information:

- Aluminum housing finished with corrosion free powder coat
- Even light distribution
- Lightweight for easier installation
- Super slim only 1" thick!

Driver Options:

- 1x1 & 1x2: 120V Triac Dimmable
- 2x2, 2x4, 1x4: 120-277V 0-10V Dimmable
- THD: <15% (=/-5% tolerance), PF >0.9, 50/60Hz
- Isolated Driver
- Flicker Free

Mounting & Installations:

- 30/40 Junction Box
- Surface mount bracket included

Certifications:

- UL Listed for USA and CA
- 1x1 & 1x2: Energy Star Certified
- 2x2, 1x4, & 2x4: DLC Listed
- Approved for CA T24
- 5 Year Limited Warranty
- FCC CFR 47, GCC Part 15, Subpart B:2017

Series	Finish ¹
LED-PNL-SM-1X1-18W-5CCT 18W • 1,500lm • 120V	(blank)
LED-PNL-SM-1X2-22W-5CCT 22W • 2,000lm • 120V	White BL ¹
LED-PNL-SM-2X2-40W-TRI 40W • 4,000lm • 120-277V	Black GRY ¹
LED-PNL-SM-2X4-50W-TRI 50W • 5,000lm • 120-277V	Gray BRZ ¹
LED-PNL-SM-1X4-40W-TRI 40W • 4,000lm • 120-277V	Bronze CS ¹
	Custom Color

1. Standard quick ship finish is white. Other colors are custom finishes

Optional Accessories (Order Separately)
Emergency Backup
LED-EMB-25W-HV-0/10V-2P 25W Emergency Backup

Specs and model numbers are subject to change with or without notice. Customization of product is available.

Internal-Line: Surface Mount LED Panels

Only 1" Thick!

FEATURES

CCT or 3-CCT-5
Selectable

Powder-Coated
White Frame

Frosted Lens

Unique Edge-Lit Design

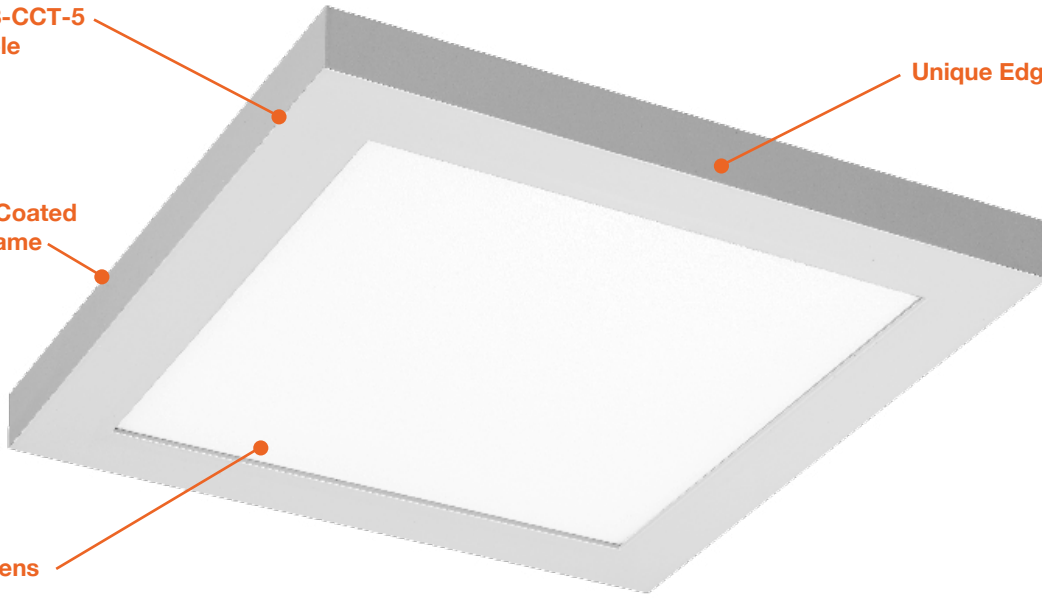

DIMENSIONS

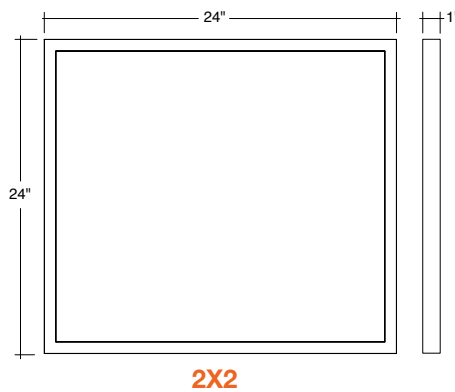
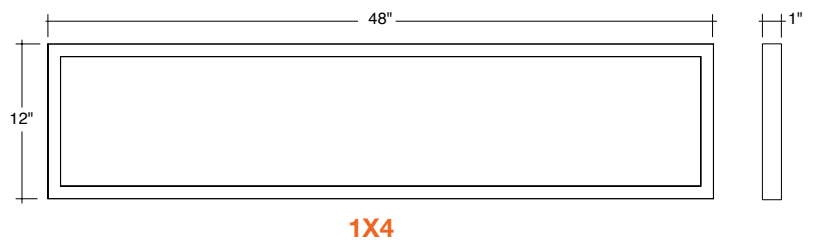
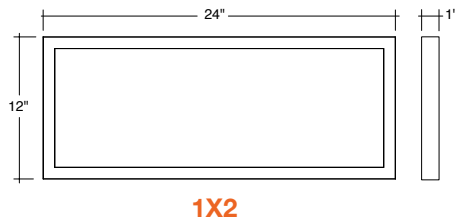
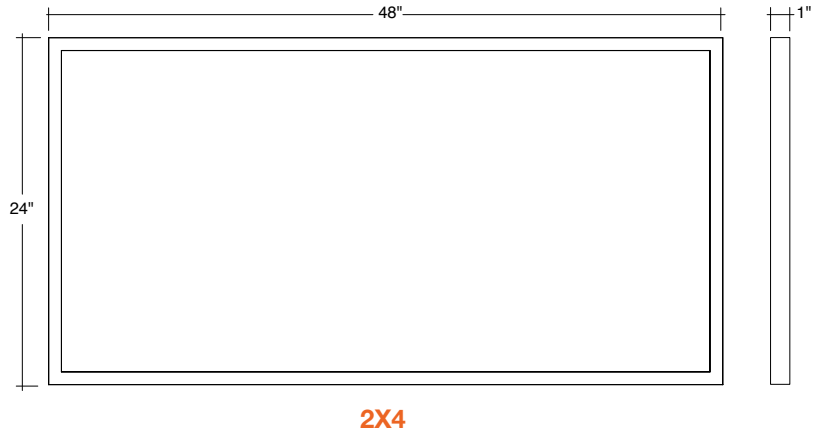
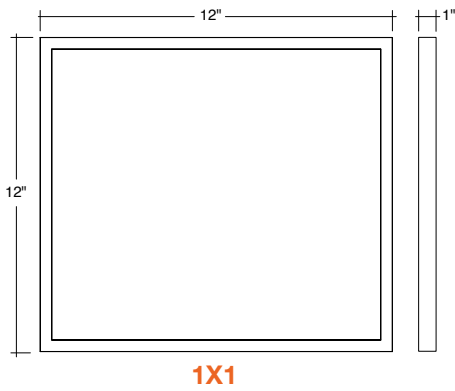

Internal-Line: Surface Mount LED Panels Only 1" Thick!

ACCESSORIES

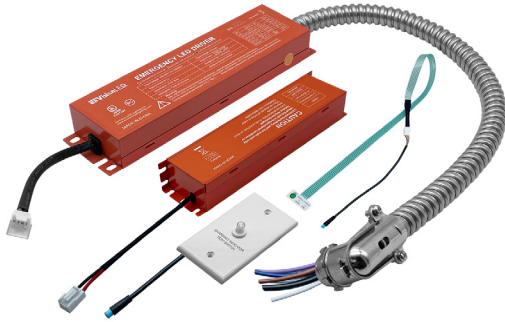

LED-EMB-25W-HV-0/10V-2P

Model	Voltage	Watts	Lumens	Color	CRI
LED-PNL-SM-1X1-18W-5CCT	120V	18w	1,500	27/30/35/40/50K	>80
LED-PNL-SM-1X2-22W-5CCT	120V	22w	2,000	27/30/35/40/50K	>80
LED-PNL-SM-1X4-40W-TRI	120/277v	40w	4,000	30/40/50k	>80
LED-PNL-SM-2X2-40W-TRI	120/277v	40w	4,000	30/40/50k	>80
LED-PNL-SM-2X4-50W-TRI	120/277v	50w	5,000	30/40/50k	>80

BATTERY BACK-UP

Accessory	Description
LED-EMB-25W-HV-0/10V-2P	25W Emergency Backup