

Installation Instructions for LED Linear Fixture



To avoid the risk of fire, or electric shock this product should be installed, inspected, and maintained by a qualified electrician only. Installation should be completely by an individual familiar with the construction and operation of the luminaire. Installation of luminaire must be in accordance with nation and local building and electrical codes.

Safety Warning:

To avoid electric shock be certain electrical power is OFF before and during installation and maintenance. Luminaire must be supplied by a wiring system with an equipment grounding conductor. To avoid burning hands make sure lens and housing are cool when performing maintenance. To avoid product degradation make sure the wire supply voltage is the same as the luminaire supply. Use proper supply wiring as specified on the luminaire nameplate. Avoid use in environments containing sulfur, chlorine, or other halides, methyl acetate or ethyl acetate, cyanoacrylates, glycol ethers, formaldehyde or butadiene.

Notes:

Instructions do not cover all details and all possible product configurations. Do not restrict luminaire ventilation. Ensure LED luminaire is not covered with material that will prevent convection or conduction cooling. Ensure LED luminaire has the correct polarity before installation. Avoid exposing wiring to metal edges and sharp objects.

Maintenance:

Perform visual, electrical and mechanical inspections on a regular basis. The environment and frequency of use should determine this. However, it is recommended that check be made at least once a year. Electrically check to make sure that all connections are clean and tight. Mechanically check that all parts are properly assembled.

Installation Dimensions (Suspended)

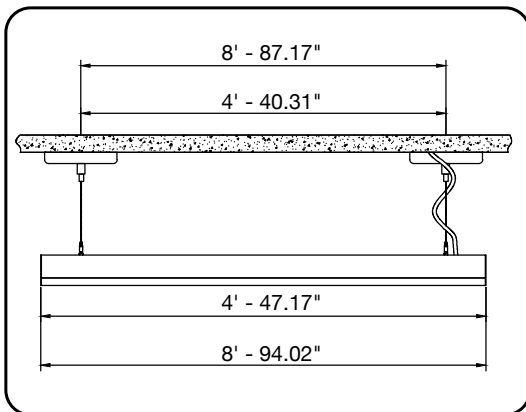

Surface Mounted

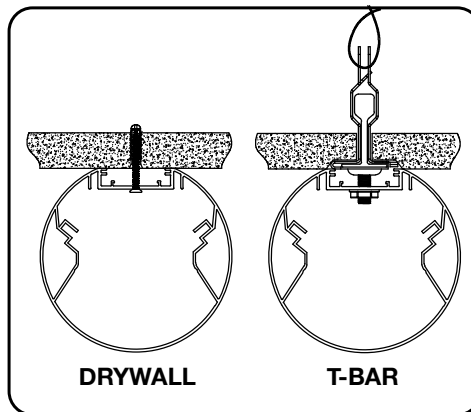

Dip Switch for 4-CCT

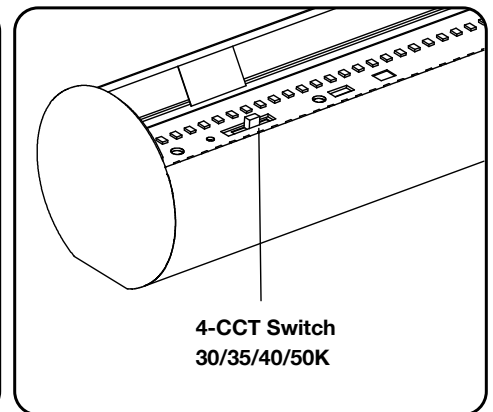

Wiring Diagram

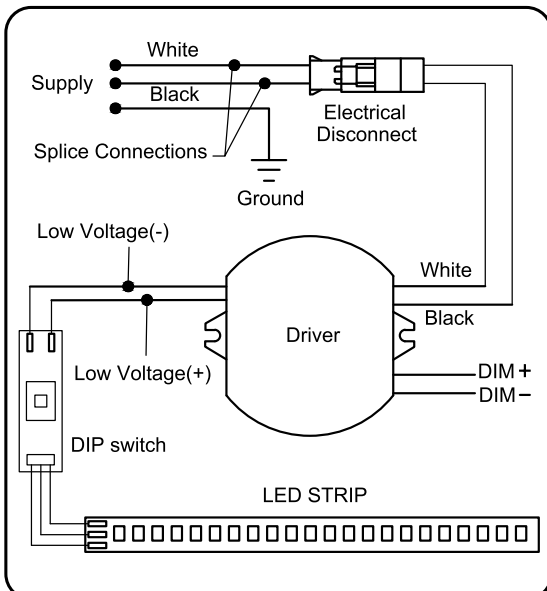

Suspended Mount

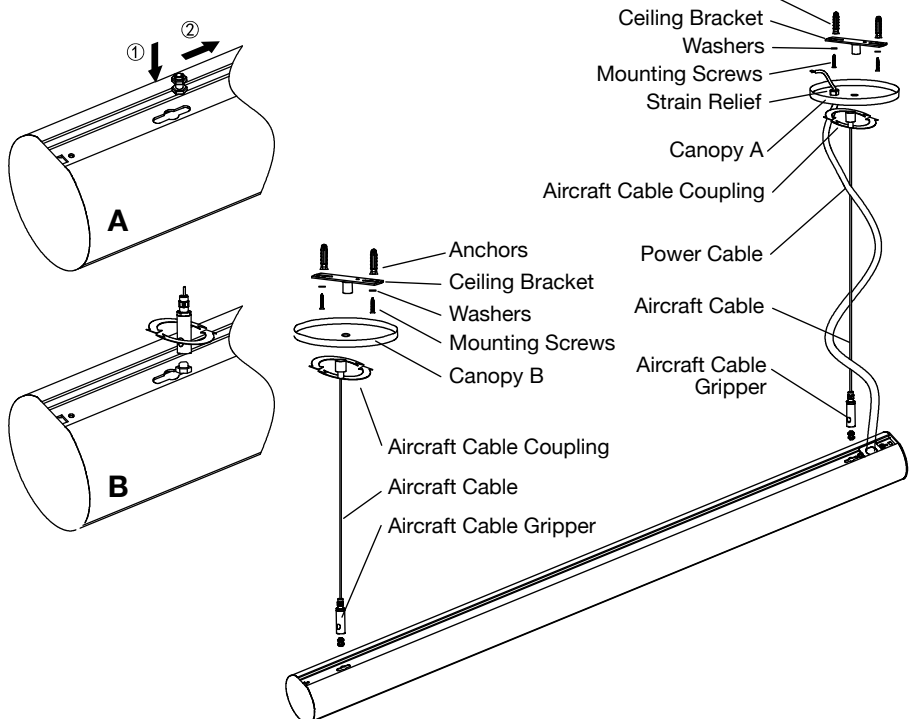

Suspended Mount (Up & Down Lighting Version)

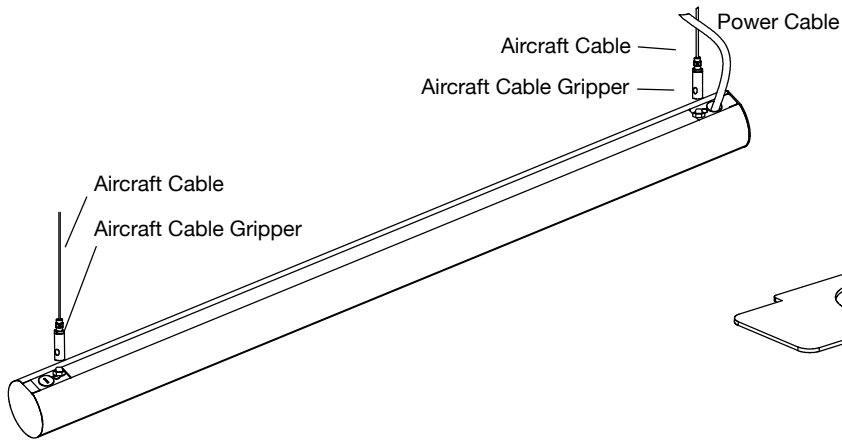

Installation Dimension		
4ft	1075mm/42.32inch	
8ft	2265mm/89.17inch	

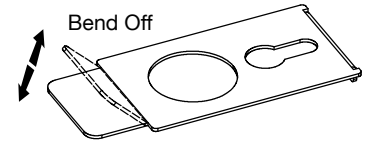
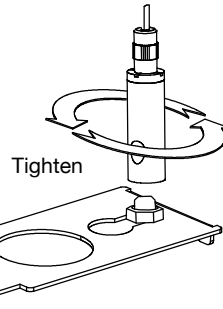

When connection is necessary, Bend off end.

Connection - A

1. Connect the fixture on the back first

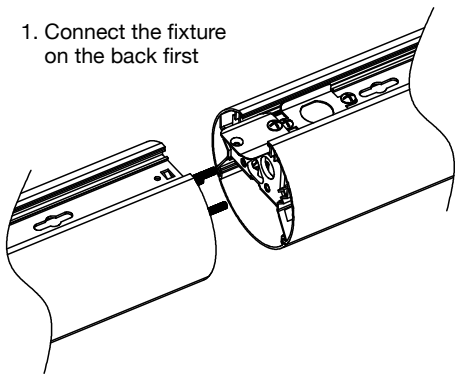

Step 1: Take off the lens and end cap

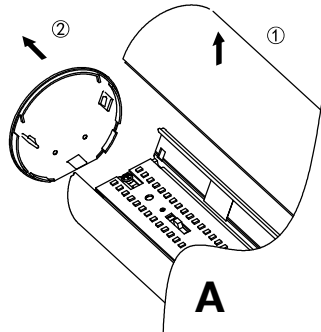

Step 2: Take off reflector

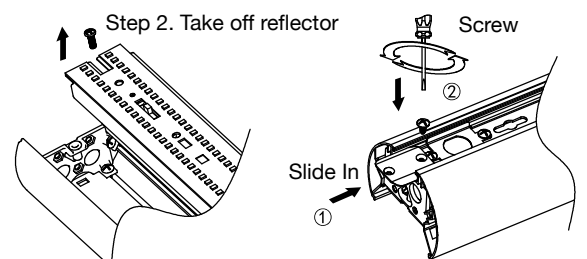

Step 3: Slide in the connection plate and screw with fixture properly

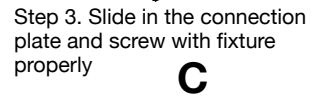

2. Connect the inner cap together

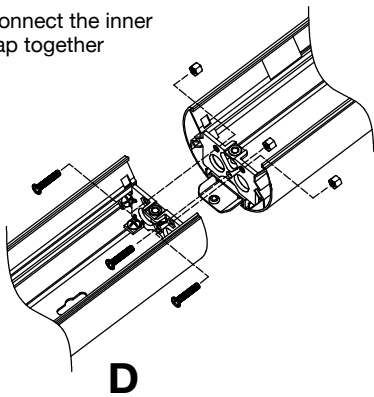

Step 1: Use the screw 3xUNC8-32 connect the inner end

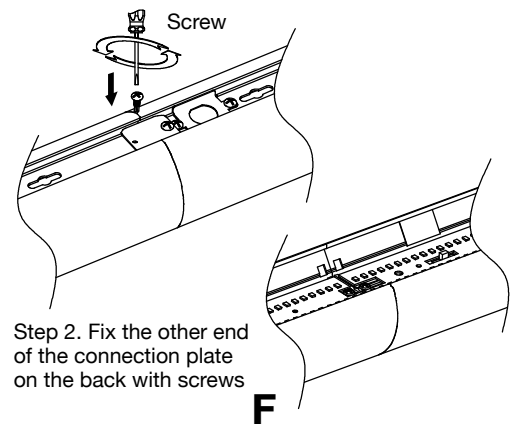
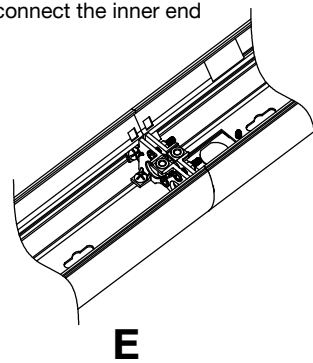

Connection - B

