

# Full Cut Off Wall Packs: Full-FC-Line

3-CCT + 3-Power + Selectable Photocell

**NEW** E.T.A. 07/2024



### Detail Specifications:

- Finish: Bronze or Black, Custom finishes available
- IP Rating: Wet Location
- Beam Angle: 90°
- BUG:
  - 3P100W: B3-U3-G3
- Traditional + Full Cut Off Mode
- Chip: SMD 2835, R9 >50, CRI >80
- Operating Temperature: -4° - 122° F
- Lens:
  - Front: PC Ribbed Lens
  - Bottom: PC w/ Optics
- Average life (L70) of 70,000 hours

### Applications:

- Walkways & Pathways
- Parking Lots
- Hospitality, Multi-Family
- Outdoor Corridors
- Residential, Commercial and Industrial

### Product Information:

- Sturdy die-cast aluminum housing finished with corrosion free powder coat
- Slim in size and easy to install
- Photocell is included with an easy quick disconnect
- Instant-On to full brightness

### Driver Options:

- UNV: 120-277V 0-10V Dimmable
- HV: 277-480V 0-10V Dimmable
- Built in 6Kv Surge Protector
- THD: <20% (+/-5% tolerance), PF >0.9, 50/60Hz

### Mounting & Installation:

- Five 1/2" knockouts: 1 one each side for convenient installation

### Certifications:

- UL Listed for USA and CA
- DLC Listed
- ROHS Compliant
- Approved for CA T24
- 5 Year Limited Warranty
- FCC CFR 47, GCC Part 15, Subpart B:2017



WATT	LUMENS
60	8,100
80	10,800
100	13,500

Series	Finish <sup>1</sup>	Voltage	Photocell	Sensor <sup>2</sup>	Emergency	Surge Protector	Optional Accessories (Order Separately)	
LED-WPF-FC-21-3P100-TRI -			- PC Photocell is included.				Remote for Sensors	Shield
	<b>BZ</b> Bronze (Standard)	<b>UNV</b> 120-277V		<b>(blank)</b> No Sensor	<b>(blank)</b> No Emergency	<b>(blank)</b> 6KV Built in		
	<b>BL</b> Black (Standard)	<b>HV</b> 277-480V		<b>BMS</b> Bi-Level Motion + Daylight Sen- sor (S-BMS- EXT-1)	<b>EMB</b> Emergency Backup	<b>20KV</b> 20KV Surge Protector	<b>S-LINE-R</b> S-Line Remote	<b>WPF-SL-SHIELD</b> Shield
	<b>WH<sup>1</sup></b> White			<b>BMSBT</b> Bi-Level Motion + Daylight Sensor -Blue- tooth Control- (S-BMS- EXT-1-BT)				
	<b>GRY<sup>1</sup></b> Gray							
	<b>CS<sup>1</sup></b> Custom Color							

1. Standard quickship is bronze. Other colors are custom finishes

2. Sensors require remote for programming

# Full Cut Off Wall Packs: Full-FC-Line

3-CCT + 3-Power + Selectable Photocell

## FEATURES



PC Ribbed Lens



Photocell with Optics

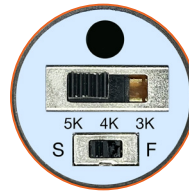

3-CCT Selectable  
+  
3-Power Selectable  
+  
Selectable Photocell

LEFT



1/2" Knockout

RIGHT



1/2" Knockout

## DIMENSIONS

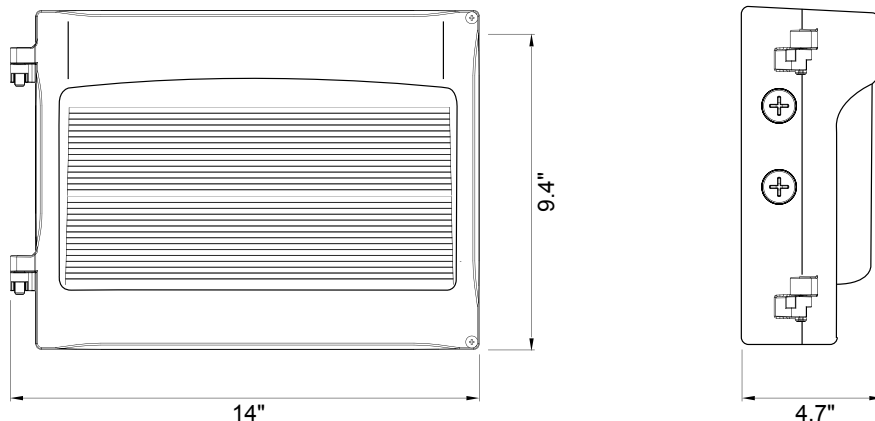

# Full Cut Off Wall Packs: Full-FC-Line

## 3-CCT + 3-Power + Selectable Photocell



**S-LINE-R**



**S-BMS-EXT-1**  
**S-BMS-EXT-1-BT**

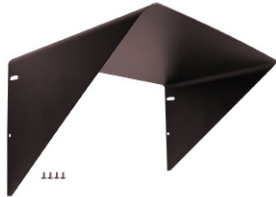

**WPF-SL-SHIELD**

### WALL PACK

Model	Voltage	Watts	Lumens	Color	CRI
LED-WPF-FC-21-3P100-TRI-BZ-PC	120-277V	100/80/60W	13,500/10,800/8,100	30/40/50k	>80
LED-WPF-FC-21-3P100-TRI-BL-PC	120-277V	100/80/60W	13,500/10,800/8,100	30/40/50k	>80

### REMOTE CONTROL

Accessory Model	Description
S-LINE-R	Remote for S-LINE Series Sensors

### HB-LINE-SENSORS

Model	Item Description	Voltage	Watts
S-BMS-EXT-1	S-Line: Bi Level Motion Sensor w/ Daylight Harvesting, Ideal for use with LED WALLPACKS. 12V 12V Aux REQD. (Remote Required)	12V	<1w
S-BMS-EXT-1-BT	S-Line: Bi Level Motion Sensor w/ Daylight Harvesting, Ideal for use with Wallpacks. 12V 12V Aux REQD. (Remote Required)	12V	<1w

### SHIELD

Accessory Model	Description
WPF-SL-SHIELD	Cout off shield