

# SL-Line: Wall Pack

## 3-CCT + 5-Power Selectable



WATT	LUMENS
30	3,900
40	5,200
60	7,800
80	10,400
100	13,000
120	15,600

### Detail Specifications:

- Finish: Bronze, Custom finishes available
- IP Rating: Wet Location
- Impact Rating: IK08
- Beam Angle: Type IV
- BUG:
  - 3P60W: B3-U3-G5
  - 3P120: B4-U4-G5
- Chip: SMD 2835, R9 >50, CRI >80
- Operating Temperature: -4° - 122° F
- Lens: Glass Lens
- Average life (L70) of 70,000 hours

### Applications:

- Walkways & Pathways
- Parking Lots
- Hospitality, Multi-Family
- Outdoor Corridors
- Residential, Commercial and Industrial

### Product Information:

- Sturdy die-cast aluminum housing finished with corrosion free powder coat
- Slim in size and easy to install
- Photocell is included with an easy quick disconnect
- Instant-On to full brightness

### Driver Options:

- UNV: 120-277V 0-10V Dimmable
- HV: 277-480V 0-10V Dimmable
- Built in 6Kv Surge Protector
- THD: <20% (+/-5% tolerance), PF >0.9, 50/60Hz

### Mounting & Installation:

- Five 1/2" knockouts: 1 one each side for convenient installation

### Certifications:

- UL Listed for USA and CA
- DLC Listed
- ROHS Compliant
- Approved for CA T24
- 5 Year Limited Warranty
- FCC CFR 47, GCC Part 15, Subpart B:2017

Series	Finish <sup>1</sup>	Photocell	Voltage	Sensor <sup>2</sup>	Emergency	Surge Protector	Optional Accessories (Order Separately)
<b>LED-WPF-SL-3P60-TRI</b> 30/40/60W • 30/40/50K	<b>BZ</b> Bronze (Standard)	<b>PC</b> Photocell is included. Easy quick disconnect.	<b>UNV</b> 120-277V	<b>(blank)</b> No Sensor	<b>(blank)</b> No Emergency	<b>(blank)</b> 6KV Built in	<b>Remote for Sensors</b> <b>Shield</b>
<b>LED-WPF-SL-3P120-TRI</b> 80/100/120W • 30/40/50K	<b>BL</b> <sup>1</sup> Black	<b>PC</b> Easy quick disconnect. (PC-3/4-3PIN-LV)	<b>HV</b> 277-480V	<b>BMS</b> Bi-Level Motion + Daylight Sensor (HB01DMS-C)	<b>EMB</b> Emergency Backup	<b>20KV</b> 20KV Surge Protector	<b>HB03R</b> HB01DMS Remote
	<b>WH</b> <sup>1</sup> White			<b>BMS1</b> Bi-Level Motion + Daylight Sensor (S-BMS-EXT-1)			<b>WPF-SL-SHIELD</b> Shield
	<b>GRY</b> <sup>1</sup> Gray			<b>BMS1BT</b> Bi-Level Motion + Daylight Sensor -Bluetooth Control-(S-BMS-EXT-1-BT)			<b>S-LINE-R</b> S-Line Remote
	<b>CS</b> <sup>1</sup> Custom Color						

1. Standard quickship is bronze. Other colors are custom finishes

2. Sensors require remote for programming

# SL-Line: Wall Pack

3-CCT + 5-Power Selectable

## FEATURES



## DIMENSIONS

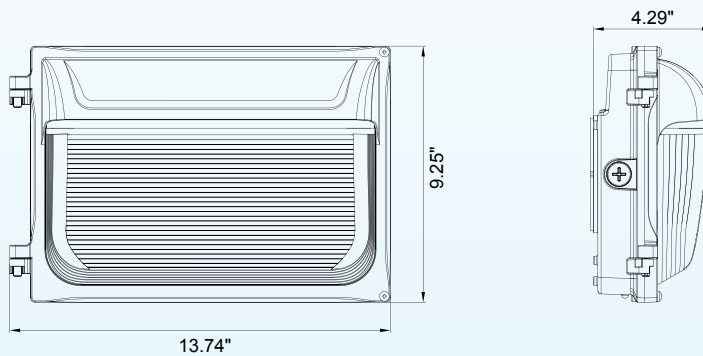

# SL-Line: Wall Pack

## 3-CCT + 5-Power Selectable



**HB03R**



**S-LINE-R**



**PC-BTN-UNV-1/2"**



**HB01DMS-C**



**S-BMS-EXT-1**  
**S-BMS-EXT-1-BT**

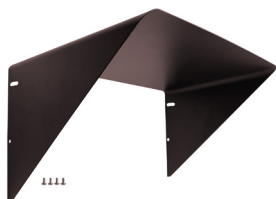

**WPF-SL-SHIELD**

### WALL PACK

Model	Voltage	Watts	Lumens	Color	CRI
LED-WPF-SL-3P60-TRI-BZ-UNV-PC	120-277V	60/40/30w	3,900/5,200/ 7,800	30/40/50k	>80
LED-WPF-SL-3P120-TRI-BZ-UNV-PC	120-277V	120/100/80w	10,400/13,000/15,600	30/40/50k	>80
LED-WPF-SL-3P60-TRI-BZ-HV-PC	277-480V	60/40/30w	3,900/5,200/ 7,800	30/40/50k	>80
LED-WPF-SL-3P120-TRI-BZ-HV-PC	277-480V	120/100/80w	10,400/13,000/15,600	30/40/50k	>80

### REMOTE CONTROL

Accessory Model	Description
HB03R	Remote for HB-Line Series
S-LINE-R	Remote for S-LINE Series Sensors

### PHOTOCELL

Accessory Model	Description
PC-BTN-UNV-1/2"	Button Photocell Universal for 1/2" Knockout

### HB-LINE-SENSORS

Model	Item Description	Voltage	Watts
HB01DMS-C	Bi Level Motion Sensor w/ Daylight Harvesting 1/2" Knockout - Includes Auxilarary	12V	<1w
S-BMS-EXT-1	S-Line: Bi Level Motion Sensor w/ Daylight Harvesting, Ideal for use with LED WALLPACKS. 12V Aux REQD. (Remote Required)	12V	<1w
S-BMS-EXT-1-BT	S-Line: Bi Level Motion Sensor w/ Daylight Harvesting, Ideal for use with Wallpacks. 12V Aux REQD. (Remote Required)	12V	<1w

### SHIELD

Accessory Model	Description
WPF-SL-SHIELD	Cout off shield